



RFID Global Solution's

SmartTable™

SmartTable™
Designed by RFID
experts who
understand your
business needs

- Rugged
- Portable
- Quick Setup
- Plug & Play
- Supports 1,000 lbs.
- Adjustable Legs
- Status Light Indicators
- Network Interfaced

The RFID enabled workspace solution that fits your requirements

Taking RFID to the next level in functionality

The RFIDGS SmartTable STHD2000 is a fully functional, fully enabled, **“Plug & Play”** reading platform which provides 6ft x 3ft of RFID-enabled workspace. The system has been engineered to isolate the read field within the boundaries of table both above and around. This translates to accurate reads of tagged items placed on or above the SmartTable™. The SmartTable is ideally suited for industrial, commercial, or retail applications.

The SmartTable™ is constructed of industrial-strength, extruded aluminum. Each unit is durable enough to withstand the toughest environments and is capable of supporting up to **1000 lb.** loads. The SmartTable meets IP64 standards and even has **adjustable legs** allowing users to level the unit virtually anywhere

The SmartTable™ is highly adaptable and can accommodate a wide array of RFID technology. Each unit comes complete with reader, antennas, **network interface**, **light indicators** and easy access panels which provide rapid equipment upgrades or replacement.

SmartTable™

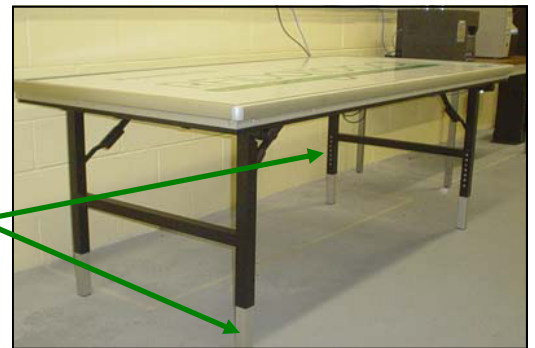

SmartTable™ | RFID enabled workspace solution

Learn more about RFID Global Solution's products and services by calling our sales team at (866) RFID-123 or email us at sales@rfidgs.com

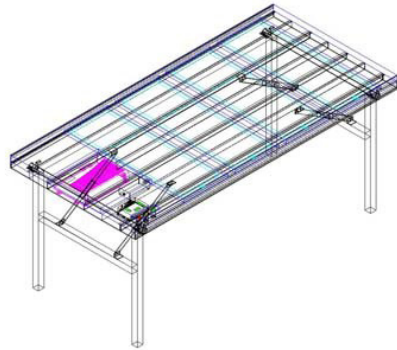

Adaptable

Units may be put back to back in environments with adjacent portals. Suitable for indoor and outdoor use (Unit is not NEMA rated).

Strong, Durable Construction

Made from the same industrial gauge aluminum that secures windows in place on skyscrapers.

Easy to Install

The SmartTable™ is designed to be installed by two people in a matter of minutes. Just fold out the legs, lock them into place stand up the table, plug in power and network and you are ready to go! It is that easy.

Innovative RFID Solution

Uniquely designed to keep the RFID read zone within the boundaries of the table ...no reads along the outside or below the table! Table read zone can be adjusted to read tags only a few inches above the table to a few feet above the table.

Optional Tabletop Covers

The heavy-duty white polymer tabletop can be customized into a sign using graphics, logos, and words. Light-Duty top can come in a variety of colors.

Warranty

The RFIDGS SmartTable™ is warranted against defects in workmanship and materials for a period of 1 year (12 months) from date of shipment, provided the product remains unmodified and is operated under normal and proper conditions.

Physical Characteristics & Specifications

Composite

Material: 6063 T5 extruded aluminum

Dimensions

Frame: 36" D x 61" L x 28"-36" H (Adjustable)
Top: 34" x 60"

Weight: 77 lbs. (35 kg)

Input Power: 110/220V

RFID: EPC Compliant
FCC Part 15 Approved
Freq: 902-928 MHz
(supports EPC Class1, Gen 2)

Reader

Interface: Powered by Motorola or Alien RFID Readers

Light

Indicators: RED-YELLOW-GREEN
Green – Unit is on
Yellow – Unit is reading
Red – Fault

Visit us at www.rfidgs.com

RFIDglobal
S O L U T I O N